

INSTYTUT TECHNIKI BUDOWLANEJ



Member of



www.eota.eu

European Technical Assessment

**ETA-19/0841
of 21/07/2023**



General Part

Technical Assessment Body issuing the European Technical Assessment

Instytut Techniki Budowlanej

Trade name of the construction product

Injection system XTREME GRIP VINYLESTER for rebar connections

Product family to which the construction product belongs

Post-installed rebar connections with injection mortar

Manufacturer

TORGGLER s.r.l.
Via Verande 1°
39012 Merano (BZ)
Italy

Manufacturing plant

TORGGLER s.r.l.
Manufacturing Plant 1

This European Technical Assessment contains

23 pages including 3 Annexes which form an integral part of this Assessment

This European Technical Assessment is issued in accordance with regulation (EU) No 305/2011, on the basis of

European Assessment Document (EAD) 330087-01-0601 "Systems for post-installed rebar connection with mortar"

This version replaces

ETA-19/0841 issued on 08/12/2020

This European Technical Assessment is issued by the Technical Assessment Body in its official language. Translations of this European Technical Assessment in other languages shall fully correspond to the original issued document and shall be identified as such.

Communication of this European Technical Assessment, including transmission by electronic means, shall be in full. However, partial reproduction may only be made with the written consent of the issuing Technical Assessment Body. Any partial reproduction has to be identified as such.

Specific Part

1 Technical description of the product

The subject of this assessment are the post-installed connections, by anchoring or overlap connection joint of steel reinforcing bars (rebar) in existing structures made of normal weight concrete, using injection mortar XTREME GRIP VINYLESTER in accordance with the regulations for reinforced concrete construction.

Reinforcing bars made of steel with diameter from 8 to 32 mm and XTREME GRIP VINYLESTER injection mortars are used for the post-installed rebar connections. The steel element is placed into a drilled hole previously filled with an injection mortar and is anchored by the bond between embedded element, injection mortar and concrete.

An illustration and the description of the products are given in Annex A.

2 Specification of the intended use in accordance with the applicable European Assessment Document (EAD)

The performances given in clause 3 are only valid if the post-installed connections are used in the compliance with the specifications and conditions given in Annex B.

The performances given in this European Technical Assessment are based on an assumed working life of the anchor of 50 years. The indications given on the working life cannot be interpreted as a guarantee given by the producer or the Technical Assessment Body, but are to be regarded only as a means for choosing the right products in relation to the expected economically reasonable working life of the works.

3 Performance of the product and references to the methods used for its assessment

3.1 Performance of the product

3.1.1 Mechanical resistance and stability (BWR 1)

Essential characteristic	Performance
Characteristic resistance under static and quasi static loading	See Annex C1
Characteristic resistance under seismic loading	See Annex C2

3.1.2 Safety in case of fire (BWR 2)

Essential characteristic	Performance
Reaction to fire	Anchorage satisfy requirements for Class A1
Resistance to fire	See Annex C3

3.2 Methods used for the assessment

The assessment has been made in accordance with EAD 330087-01-0601.

4 Assessment and verification of constancy of performance (AVCP) system applied, with reference to its legal base

According to Decision 96/582/EC of the European Commission the system 1 of assessment and verification of constancy of performance applies (see Annex V to regulation (EU) No 305/2011).

5 Technical details necessary for the implementation of the AVCP system, as provided in the applicable European Assessment Document (EAD)

Technical details necessary for the implementation of the AVCP system are laid down in the control plan deposited in Instytut Techniki Budowlanej.

For type testing the results of the tests performed as part of the assessment for the European Technical Assessment shall be used unless there are changes in the production line or plant. In such cases the necessary type testing has to be agreed between Instytut Techniki Budowlanej and the notified body.

Issued in Warsaw on 21/07/2023 by Instytut Techniki Budowlanej

A handwritten signature in blue ink, appearing to read 'Anna Panek', written in a cursive style.

Anna Panek, MSc

Deputy Director of ITB

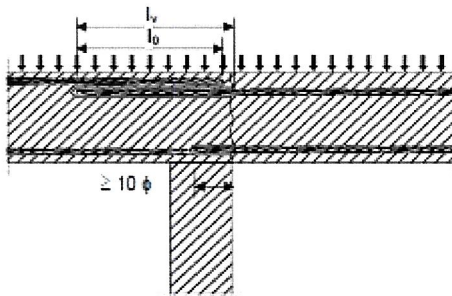
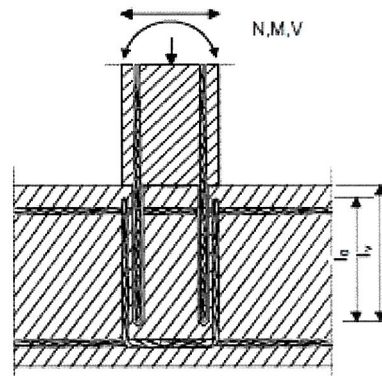
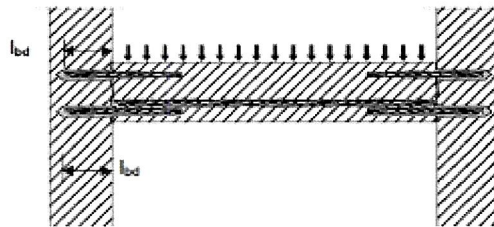
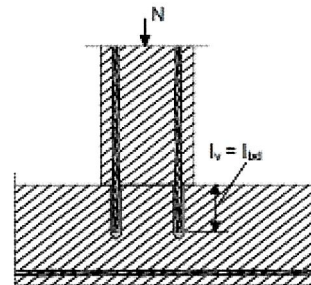
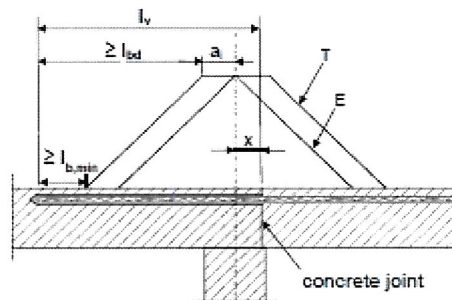
Examples of post-installed rebar connections

Figure 1.1 Overlap joint for rebar connections of slabs and beams

Figure 1.2 Overlap joint at a foundation of a column or wall where the rebar is stressed in tension

Figure 1.3 End anchoring of slabs or beams, designed as simply supported

Figure 1.4 rebar connection for components stressed primarily in compression; rebar is stressed in compression

(only post-installed rebar is plotted)

Key to Figure 1.5

- T acting tensile force
- E envelope of $M_{ed}/z + N_{ed}$ (see EN 1992-1-1, Figure 9.2)
- x distance between the theoretical point of support and concrete joint

Note to Figure 1.1 to 1.5:

In the Figures no transverse reinforcement is plotted, the transverse reinforcement as required by EN 1992-1-1 shall be present.

The shear transfer between old and new concrete shall be designed according to EN 1992-1-1.

Figure 1.5 Anchoring of reinforcement to cover the line of acting tensile force

**Injection system XTREME GRIP VINYLESTER
for rebar connections**

Product description
Application examples of post-installed rebar

Annex A1
of European
Technical Assessment
ETA-19/0841

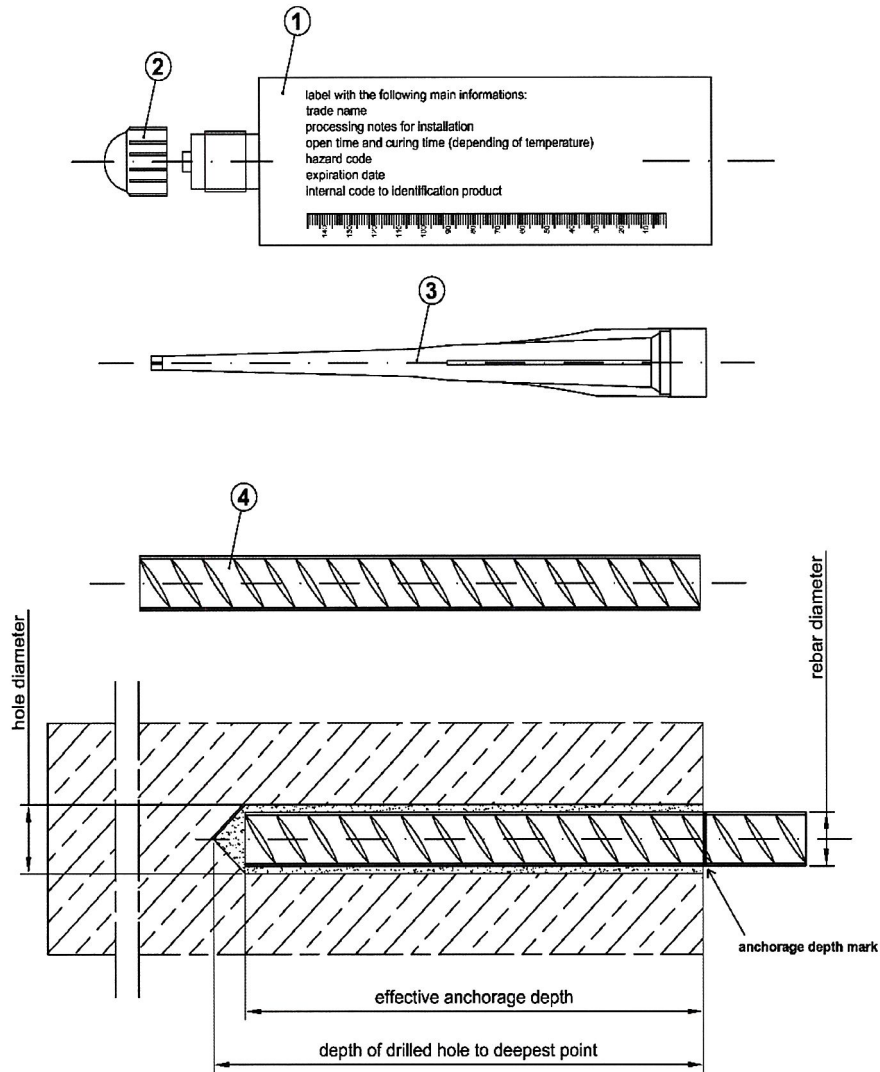

- ① Cartridge
- ② Sealing cap
- ③ Mixer
- ④ Rebar - Reinforced bar

Injection system XTREME GRIP VINYLESTER for rebar connections	Annex A2 of European Technical Assessment ETA-19/0841
Product description Injection system	

Table A1: Reinforcing bars (Rebar)

Designation	Material
Rebar according to EN 1992-1-1:2004+AC:2010	Bars and de-coiled rods Class B or C With f_{yk} and k according to EN 1992-1-1:2004+AC:2010 $f_{uk} = f_{tk} = k \times f_{yk}$ The rib height h : $h \leq 0,07 \varnothing$

Table A2: Injection mortar

Product	Composition
XTREME GRIP VINYLESTER (two component injection mortar)	Additive: quartz Bonding agent: vinyl ester resin styrene free Hardener: dibenzoyl peroxide

**Injection system XTREME GRIP VINYLESTER
for rebar connections**

Product description
Materials

Annex A3
of European
Technical Assessment
ETA-19/0841

coaxial cartridge - sizes from 75 ml to 420 ml

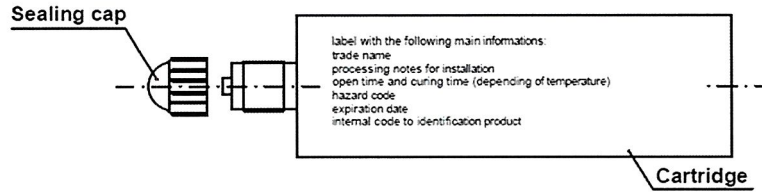

side by side cartridge - sizes from 345 ml to 825 ml

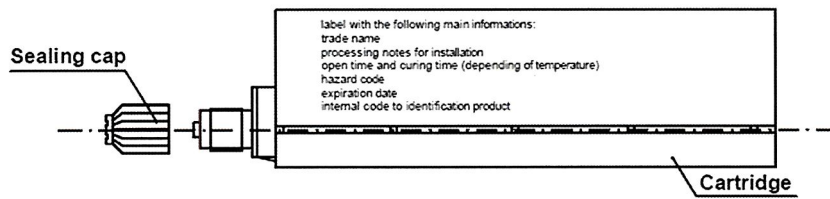

CIC foil cartridge - sizes from 165 ml to 300 ml

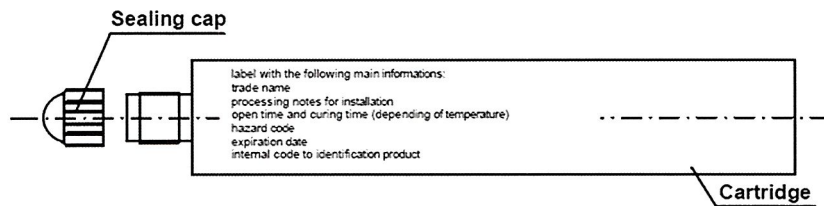

coaxial peeler cartridge - size of 280 ml

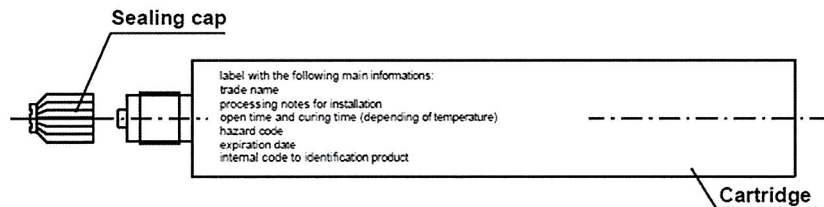

MIXER - the mixer is suitable for each type of cartridge

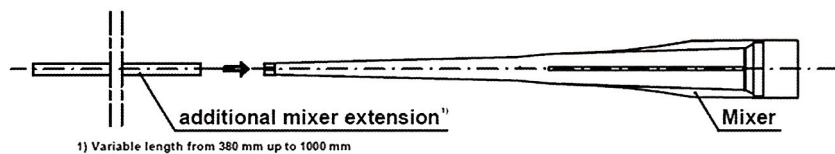

**Injection system XTREME GRIP VINYLESTER
for rebar connections**

**Product description
Cartridge types**

**Annex A4
of European
Technical Assessment
ETA-19/0841**

Specification of intended use
Anchorage subject to:

Static and quasi-static load: from Ø8 to Ø32 mm.

Seismic load: from Ø12 to Ø32 mm.

Fire exposure: from Ø8 to Ø32 mm.

Base material:

- Reinforced or unreinforced normal weight concrete of strength class C12/15 at minimum to C50/60 at maximum according to EN 206 for static and quasi-static load and for fire exposure.
- Reinforced or unreinforced normal weight concrete of strength class C16/20 at minimum to C50/60 at maximum according to EN 206 for seismic load.
- Maximum chloride content of 0,40% (Cl 0,40) related to the cement content according to EN 206.
- Non-carbonated concrete.

Note: In case of a carbonated surface of the existing concrete structure the carbonate layer shall be removed in the area of the post-installed rebar connection with a diameter of $d_s + 60$ mm prior to the installation of the new rebar. The depth of concrete to be removed shall correspond to at least the minimum concrete cover according to EN 1992-1-1:2004+AC:2010.

The above may be neglected if building components are new and not carbonated and if building components are in dry conditions.

Temperature range:

The products may be used in the following temperature range:

- -40°C to +80°C (max. short term temperature +80°C and max. long term temperature +50°C).

Temperature of the base material according to Annex B4.

Design:

- Anchorages are designed under the responsibility of an engineer experienced in anchorages and concrete work.
- Verifiable calculation notes and drawings are prepared taking into account of the forces to be transmitted.
- Design according to EN 1992-1-1:2004+AC:2010 for static and quasi-static condition (see also Annex B2).
- Design according to EN 1998-1:2004+AC:2009 for seismic condition (see also Annex B2).
- The actual position of the reinforcement in the existing structure shall be determined on the basis of the construction documentation and taken into account when designing.

Installation:

- Dry or wet concrete.
- It must not be installed in flooded holes.
- Overhead installation is permissible.
- Hole drilling by hammer drill (HD), hollow drill bit (HDB) or compressed air drill (CA).
- Installation of the post-installed rebar shall be done only by suitable trained installer and under supervision on the site.
- Check the position of the existing rebar (if the position of existing rebar in not known it shall be determined using a rebar detector suitable for this purpose as well as on the basis of the construction documentation and then marked on the building component for the overlap joint).

**Injection system XTREME GRIP VINYLESTER
for rebar connections**

**Intended use
Specifications**

**Annex B1
of European
Technical Assessment
ETA-19/0841**

General design rules of construction for post-installed rebar

Post installed rebar may be designed for tension forces only.

The transfer of shear forces between new concrete and existing structure shall be designed additionally according to EN 1992-1-1:2004+AC:2010.

The joints for concreting must be roughened to at least such an extent that aggregate protrude.

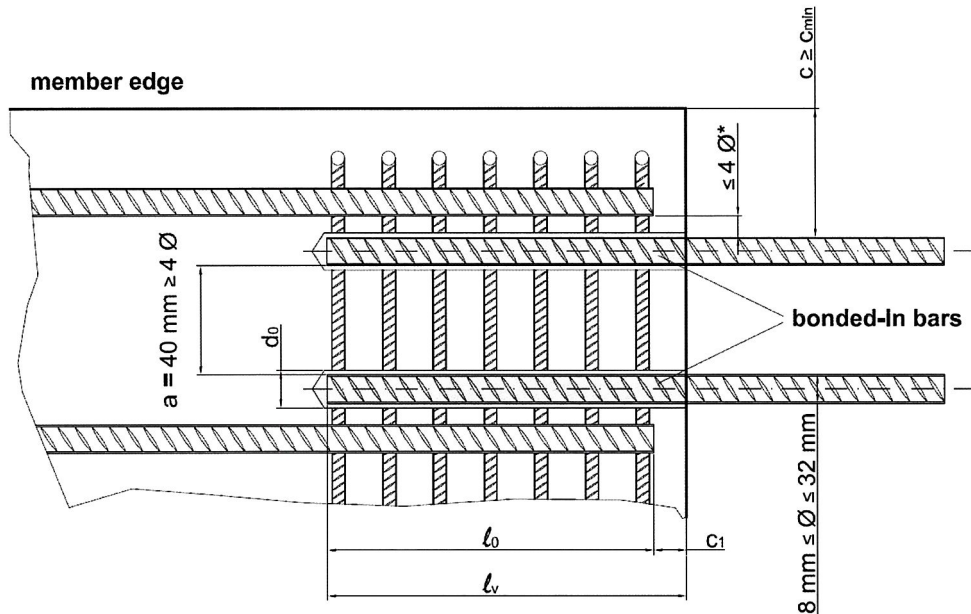

* If the clear distance between overlapping rebar is greater than $4 \cdot \emptyset$ the overlap length shall be enlarged by the difference between the clear distance and $4 \cdot \emptyset$.

- l_0 lap length according to EN 1992-1-1:2004+AC:2010 for static and quasi-static loading or EN 1998-1:2004+AC:2009 for seismic loading
- l_v effective embedment depth; $l_v \geq l_0 + c_1$
- c concrete cover of post-installed rebar
- c_{min} minimum concrete cover according to Annex B3 and EN 1992-1-1:2004+AC:2010
- c_1 concrete cover at end-face of existing rebar
- d_0 nominal drill bit diameter according to Annex B3
- \emptyset rebar diameter (d_s)

**Injection system XTREME GRIP VINYLESTER
for rebar connections**

Intended use
General construction rules for post-installed rebars

Annex B2
of European
Technical Assessment
ETA-19/0841

Table B1-1: Installation parameters for static and quasi static loading

Rebar diameter [mm]	Ø8		Ø10		Ø12		Ø14	Ø16	Ø20	Ø22	Ø25	Ø28	Ø30	Ø32
Drill bit diameter [mm]	10 ¹⁾	12 ¹⁾	12 ¹⁾	14 ¹⁾	14 ¹⁾	16 ¹⁾	18	20	25	26	30	35	35	40
Brush diameter [mm]	12	14	14	16	16	18	20	22	27	27	32	37	37	42
Maximum embedment depth $l_{v, max}$ [mm]	250	400	250	500	250	600	700	800	1000	1000	1000	1000	1000	1000

¹⁾ Each of two given values can be used

Table B1-2: Installation parameters for seismic loading

Rebar diameter [mm]	Ø12	Ø14	Ø16	Ø20	Ø22	Ø25	Ø28	Ø30	Ø32
Drill bit diameter [mm]	16	18	20	25	26	30	35	35	40
Brush diameter [mm]	18	20	22	27	27	32	37	37	42
Maximum embedment depth $l_{v, max}$ [mm]	600	700	800	1000	1000	1000	1000	1000	1000

Table B2: Minimum concrete cover c_{min} without drilling aid

Drilling method	Rebar diameter Ø	c_{min}
Hammer drilling (HD) Hollow drill bit (HDB)	< 25 mm	30 mm + 0,06 x l_v ≥ 2φ
	≥ 25 mm	40 mm + 0,06 x l_v ≥ 2φ
Compressed air drilling (CA)	< 25 mm	50 mm + 0,08 x l_v
	≥ 25 mm	60 mm + 0,08 x l_v ≥ 2φ

Table B3: Minimum concrete cover c_{min} when using a drilling aid

Drilling method	Rebar diameter Ø	c_{min}
Hammer drilling (HD) Hollow drill bit (HDB)	< 25 mm	30 mm + 0,02 x l_v ≥ 2φ
	≥ 25 mm	40 mm + 0,02 x l_v ≥ 2φ
Compressed air drilling (CA)	< 25 mm	50 mm + 0,02 x l_v
	≥ 25 mm	60 mm + 0,02 x l_v ≥ 2φ

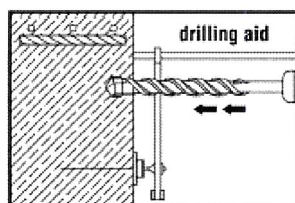

Example of drilling aid

The minimum concrete cover according to 1992-1-1:2004+AC:2010 shall be observed.

Minimum clear spacing between two post-installed rebar:
 $a = 40 \text{ mm} \geq 4 \times \varnothing$

**Injection system XTREME GRIP VINYLESTER
for rebar connections**

Intended use
Installation parameters

Annex B3
of European
Technical Assessment
ETA-19/0841

Table B4: Maximum processing time and minimum curing time

XTREME GRIP VINYLESTER		
Concrete temperature [C°]	Processing time [min.]	Minimum curing time¹⁾ [min.]
-5	65	780
0	45	420
+5	25	90
+10	16	60
+15	11,5	45
+20	7,5	40
+25	5	35
+30	3	30
+35	2	25
+40	1	20

¹⁾ The minimum time from the end of the mixing to the time when the rebar may be loaded. Minimum resin temperature for installation +5°C. Maximum resin temperature for installation +30°C. For wet condition the curing time must be double.

**Injection system XTREME GRIP VINYLESTER
for rebar connections**

Intended use
Maximum processing time and minimum curing time

Annex B4
of European
Technical Assessment
ETA-19/0841

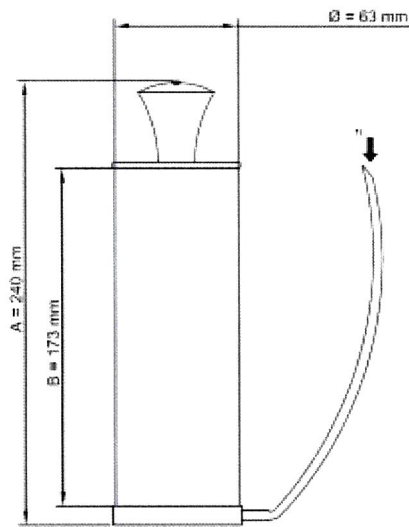
Manual Blower pump: nominal dimensions

It is possible to use the mixer extension with the manual blower pump.

However it is possible to blow the hole using the mechanical air system (compressed air) also with the mixer extension



Suitable min pressure 6 bar at 6 m³/h
 Oil-free compressed air
 Recommended air gun with an orifice opening of minimum 3.5 mm in diameter

1) Position to insert the mixer extension

Mixer extension (from 380 mm to 1000 mm) with nominal diameter 8 or 10 mm

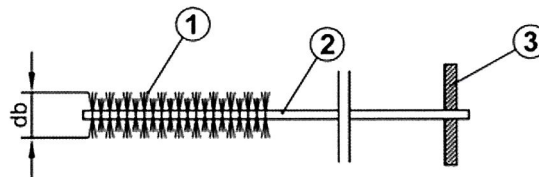

- ① Steel bristles
- ② Steel stem
- ③ Wood handle

Table B5: Standard brush details (manual brush)

Rebar diameter [mm]		Ø8		Ø10		Ø12		Ø14	Ø16
d₀	Nominal drill hole [mm]	10 ¹⁾	12 ¹⁾	12 ¹⁾	14 ¹⁾	14 ¹⁾	16 ¹⁾	18	20
d_b	Brush diameter [mm]	12	14	14	16	16	18	20	22

¹⁾ Each of two given values can be used

**Injection system XTREME GRIP VINYLESTER
 for rebar connections**

Intended use
 Cleaning tools (1)

Annex B5
 of European
 Technical Assessment
 ETA-19/0841

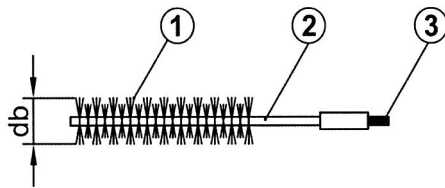

- ① Steel bristles
- ② Steel stem
- ③ Threaded connection for drilling tool extension
- ④ Extension special brush
- ⑤ Drilling tool connection (SDS connection)

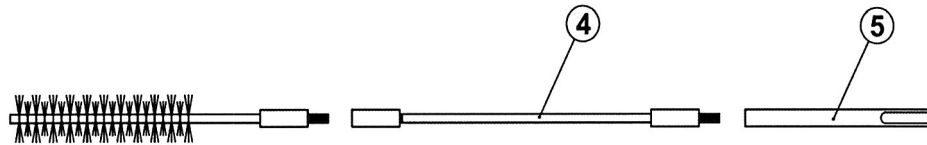

Table B6: Special brush details (mechanical brush)

Rebar diameter [mm]		Ø8		Ø10		Ø12		Ø14	Ø16	Ø20	Ø22	Ø25	Ø28	Ø30	Ø32
d₀	Nominal drill hole [mm]	10 ¹⁾	12 ¹⁾	12 ¹⁾	14 ¹⁾	14 ¹⁾	16 ¹⁾	18	20	25	26	30	35	35	40
d_b	Brush diameter [mm]	12	14	14	16	16	18	20	22	27	27	32	37	37	42

¹⁾ Each of two given values can be used

Injection system XTREME GRIP VINYLESTER for rebar connections	Annex B6 of European Technical Assessment ETA-19/0841
Intended use Cleaning tools (2)	

Installation with hollow drill bit (HDB)

This drilling method is a hammer drilling method.

This drilling system removes the dust and cleans the bore hole during the drilling operation when used in accordance with the user's manual.

This drilling system include a vacuum cleaner. A suitable dust extraction system must be used.
e.g. Bosch GAS 35 M AFC or a comparable dust extraction system with equivalent performance data.

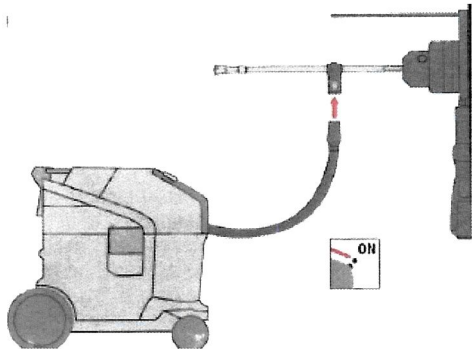

Switch-on the vacuum cleaner before to drill



Table B7: HDB installation diameters

Rebar diameter [mm]		Ø8	Ø10	Ø12	Ø14	Ø16	Ø20	Ø25	Ø28	Ø30
d ₀	Nominal drill hole [mm]	10 ¹⁾ 12 ¹⁾	12 ¹⁾ 14 ¹⁾	14 ¹⁾ 16 ¹⁾	18	20	25	30	35	35

¹⁾ Each of two given values can be used

**Injection system XTREME GRIP VINYLESTER
for rebar connections**

Intended use
Hollow drill bit (HDB) specification

Annex B7
of European
Technical Assessment
ETA-19/0841

Use the mixer extension (assembled on the standard mixer) for the injection up to 300 mm if necessary.

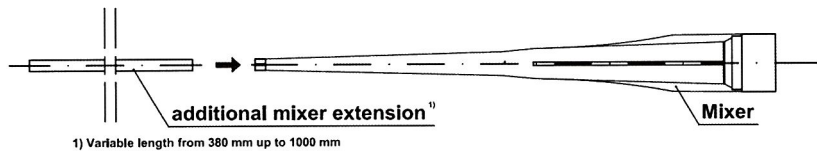

Use this system for special conditions.

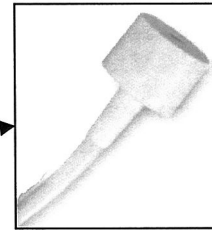
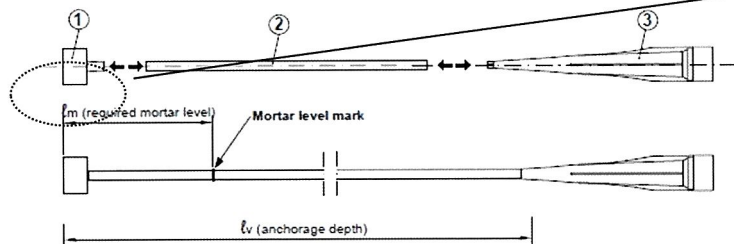

Insert the special mixer extension in the inner diameter of the injection plug up to reach the top of the plug

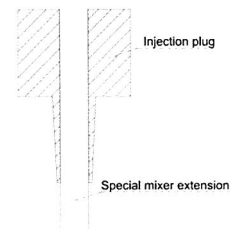

- ① Injection plug (nominal diameter according to the nominal diameter of drilled hole)
- ② Special mixer extension (variable length with external diameter 10 mm)
Mark the required mortar level ℓ_m and embedment depth ℓ_v with tape or marker on the injection extension. Quick estimation: $\ell_m = 1/3 \cdot \ell_v$
Continue injection until the mortar level mark ℓ_m becomes visible.
- ③ Mixer (suitable for all size of cartridge)

These tools allow the application in special conditions:
- installation with anchorage depth greater than 300 mm;
- overhead installation.

For these applications it is recommended the use of pneumatic or battery dispenser.

System assembled

- ① Injection plug
- ② Special mixer extension
- ③ Mixer
- ④ Cartridge
- ⑤ Sample of dispenser

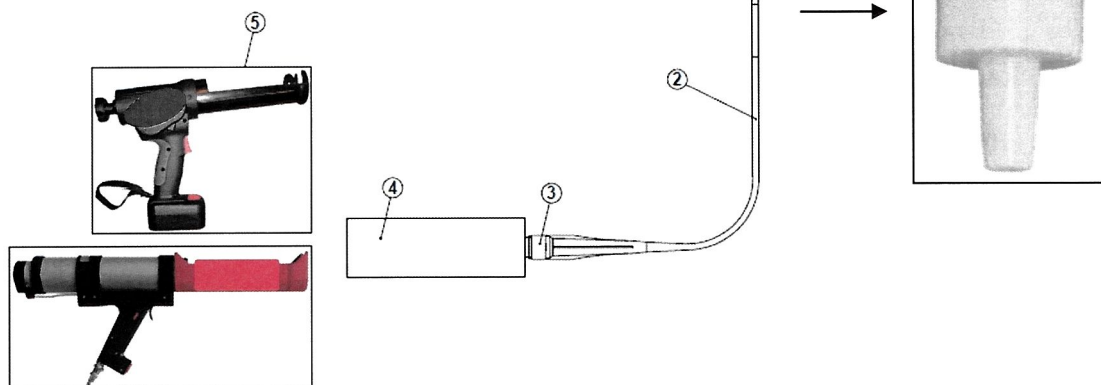

**Injection system XTREME GRIP VINYLESTER
for rebar connections**

Product description
Tools for installation (1)

Annex B8
of European
Technical Assessment
ETA-19/0841

Table B8: Mortar injection pumps

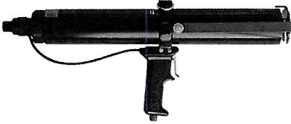
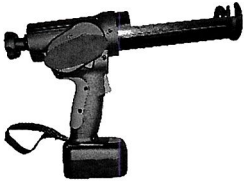
Pumps (injection dispensers)	Cartridges	Clean hole tools	Depth of the drill hole
 <i>Manual</i>	420 ml 400 ml 380 ml	Blower pump or compressed air and standard brush or special brush or HDB	to 300 mm
 <i>Manual</i>	345 ml 300 ml 280 ml 165 ml	Blower pump or compressed air and standard brush or special brush or HDB	to 300 mm
 <i>Manual</i>	300 ml 280 ml 165 ml	Blower pump or compressed air and standard brush or special brush or HDB	to 300 mm
 <i>Pneumatic</i>	825 ml	Compressed air and special brush or HDB	300 mm to 1000 mm*
 <i>Pneumatic</i>	420 ml 400 ml 380 ml	Compressed air and special brush or HDB	300 mm to 1000 mm*
 <i>Battery</i>	420 ml 400 ml 380 ml 345 ml	Compressed air and special brush or HDB	300 mm to 1000 mm*

* Note: use the mixer extension described in Annex B8 for the injection of the mortar

**Injection system XTREME GRIP VINYLESTER
for rebar connections**

Intended use
Tools for installation (2)

Annex B9
of European
Technical Assessment
ETA-19/0841

<p>1</p>		<p>Drill the hole with the correct diameter and depth using a rotary percussive machine. Check the perpendicularity of the hole during the drilling operation. In case of use of hollow drill bit (Annex B7) proceed directly to the point 3.</p>
<p>2</p>	<p>4x blower manual pump 4x standard brush 4x blower manual pump</p> <p>if necessary use a mixer extension for the blower operation (see Annex B8)</p>	<p>Clean the hole from drilling dust: the hole shall be cleaned by at least 4 blowing operations, by at least 4 brushing operations followed again by at least 4 blowing operations; before brushing clean the brush and check (see Annex B5, standard brush) if the brush diameter is sufficient. For the blower tools see Annex B5.</p>
<p>3</p>		<p>For coaxial, peeler and side by side cartridges unscrew the front cup, screw on the mixer and insert the cartridge into the gun. For CIC sizes, unscrew the front cup, pull-out the steel closing clip according to the following operation:</p> <ol style="list-style-type: none"> 1) Insert the mixer in the eye of the plastic extractor; 2) Pull the extractor to unhook the steel closing clip of the foil. In the version without the extractor cut the foil pack. <p>After that screw on the mixer and insert the cartridge in the gun.</p>
<p>4</p>		<p>Before starting to use the cartridge, eject a first part of the product, being sure that the two components are completely mixed. The complete mixing is reached only after that the product, obtained by mixing the two components, comes out from the mixer with a uniform colour.</p>
<p>5</p>	<p>if necessary, use a mixer extension for the injection (see Annex B8)</p>	<p>Fill the drilled hole uniformly starting from the drilled hole bottom, in order to avoid entrapment of the air; remove the mixer slowly bit by bit during pressing-out; filling the drill hole with a quantity of the injection mortar corresponding to 2/3 of the drill hole depth.</p>
<p>6</p>	<p>ATTENTION Use rebars dry and free oil and other contaminants</p>	<p>Insert immediately the rebar, marked according to the proper anchorage depth, slowly and with a slight twisting motion, removing excess of injection mortar around the rebar. Observe the processing time according Annex B4. Wait the curing time according Annex B4.</p>
<p>Injection system XTREME GRIP VINYLESTER for rebar connections</p>		<p>Annex B10 of European Technical Assessment ETA-19/0841</p>
<p>Intended use Installation instruction up to 300 mm depth</p>		

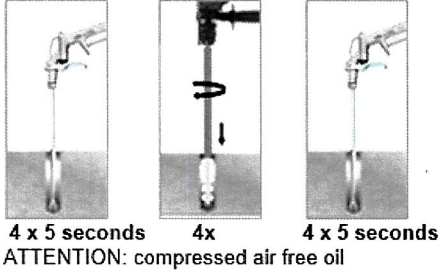
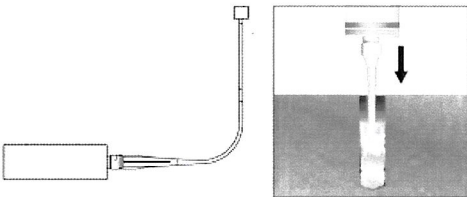
<p>1</p>	<p>See point 1 Annex B10. In case of use of hollow drill bit (HDB) proceed directly to the point 3.</p>	
<p>2</p>	 <p>4 x 5 seconds 4x 4 x 5 seconds ATTENTION: compressed air free oil</p>	<p>Clean the hole from drilling dust: the hole shall be cleaned by at least 4 blowing operations (5 seconds for single operation) with compressed air, by at least 4 brushing operations with special brush followed again by at least 4 blowing operations (5 seconds for single operation) with compressed air. Before brushing clean the brush and check if the brush diameter is sufficient (see Annex B6).</p>
<p>3</p>	<p>See point 3 Annex B10</p>	
<p>4</p>	<p>See point 4 Annex B10</p>	
<p>5</p>		<p>Before starting the injection, assemble the system according to Annex B8. After that, fill the drilled hole uniformly from the drilled hole bottom, in order to avoid entrapment of the air; remove the special mixer extension with injection plug slowly bit by bit during pressing-out; filling the drill hole with a quantity of the injection mortar corresponding to 2/3 of the drill hole depth.</p>
<p>6</p>	<p>See point 6 Annex B10</p>	
<p>Injection system XTREME GRIP VINYLESTER for rebar connections</p>		<p>Annex B11 of European Technical Assessment ETA-19/0841</p>
<p>Intended use Installation instruction up to 1000 mm depth</p>		

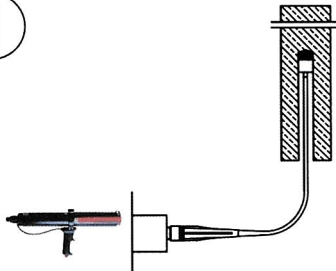
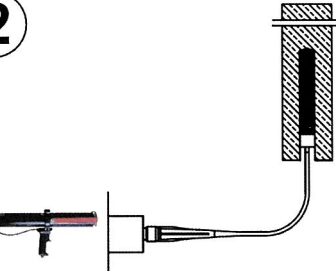
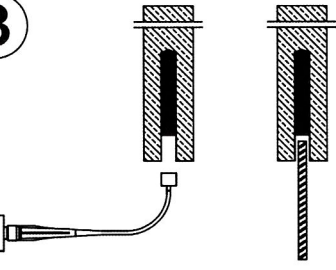
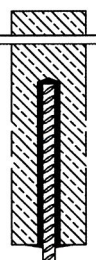
<p>1</p> 	<p>1 - Start injection</p> <p>Inject from the bottom of the hole. Maintain this position during the injection phase.</p>
<p>2</p> 	<p>2 - Injection phase</p> <p>Inject the product about 2/3 of the hole depth. During the injection maintain this position to assure the correct installation</p>
<p>3</p> 	<p>3 - End injection</p> <p>Remove the injection plug. Insert immediately the rebar (turn the rebar during the insertion).</p>
<p>4</p> 	<p>4 - End installation</p> <p>To avoid the slipping of the rebar during the open time of the product (due to the rebar own weight) use a temporary interlocking element (for ex. wedge of wood)</p>

**Injection system XTREME GRIP VINYLESTER
for rebar connections**

Intended use
Overhead installation instruction

Annex B12
of European
Technical Assessment
ETA-19/0841

Minimum anchorage length and minimum lap length under static loading

The minimum anchorage length $l_{b,min}$ and the minimum lap length $l_{0,min}$ according to EN 1992-1-1:2004+AC:2010 shall be multiplied by the relevant amplification factor α_{lb} given in Table C1.

The design bond strength $f_{bd,PIR}$ is given in Table C3. It is obtained by multiplying the bond strength f_{bd} according to EN 1992-1-1:2004+AC:2010 with the factor k_b according to Table C2.

Table C1: Amplification factor α_{lb} related to the concrete class and drilling method

Concrete class	Drilling method	Bar size	Amplification factor α_{lb}
C12/15 to C50/60	Hammer drilling (HD), hollow drill bit (HDB) and compressed air drill (CA)	8 mm to 32 mm	1,0

Table C2: Bond efficiency factor k_b related to concrete class and drilling method

k_b for perforation with hammer drill (HD), hollow drill bit (HDB) and compressed air drill (CA)	Concrete class								
	C12/15	C16/20	C20/25	C25/30	C30/37	C35/45	C40/50	C45/55	C50/60
Ø8 to Ø14	1,00	1,00	1,00	1,00	1,00	1,00	1,00	1,00	1,00
Ø16 to Ø20	1,00	1,00	1,00	1,00	1,00	1,00	1,00	1,00	0,93
Ø22	1,00	1,00	1,00	1,00	1,00	1,00	1,00	0,92	0,93
Ø24 to Ø25	1,00	1,00	1,00	1,00	1,00	1,00	1,00	0,92	0,86
Ø28	1,00	1,00	1,00	1,00	1,00	1,00	0,91	0,84	0,79
Ø30 to Ø32	1,00	1,00	1,00	1,00	0,89	0,80	0,73	0,67	0,63

Table C3. Design values of the ultimate bond resistance $f_{bd,PIR}$ ¹⁾ according to EN 1992-1-1:2004+AC:2010 for hammer drilling (HD), hollow drill bit (HDB) and compressed air drill (CA)

Rebar diameter [mm]	Design values of the ultimate bond resistance $f_{bd,PIR}$ [N/mm ²]								
	C12/15	C16/20	C20/25	C25/30	C30/37	C35/45	C40/50	C45/55	C50/60
Ø8 to Ø14	1,60	2,00	2,30	2,70	3,00	3,40	3,70	4,00	4,30
Ø16 to Ø20	1,60	2,00	2,30	2,70	3,00	3,40	3,70	4,00	4,00
Ø22	1,60	2,00	2,30	2,70	3,00	3,40	3,70	3,70	4,00
Ø24 to Ø25	1,60	2,00	2,30	2,70	3,00	3,40	3,70	3,70	3,70
Ø28	1,60	2,00	2,30	2,70	3,00	3,40	3,40	3,40	3,40
Ø30 to Ø32	1,60	2,00	2,30	2,70	2,70	2,70	2,70	2,70	2,70

¹⁾The values given are valid for good bond condition according to EN 1992-1-1:2004+AC:2010.

For all other bond conditions multiply the value by 0,7.

**Injection system XTREME GRIP VINYLESTER
for rebar connections**

Performances
Design values of the ultimate bond resistance $f_{bd,PIR}$

Annex C1
of European
Technical Assessment
ETA-19/0841

Minimum anchor length and minimum lap length under seismic loading

The minimum anchorage length $l_{b,min}$ and the minimum lap length $l_{0,min}$ according to EN 1992-1-1:2004+AC:2010 shall be multiplied by the relevant amplification factor α_{lb} given in Table C1.

The design bond strength $f_{bd,seis}$ is given in Table C5. It is obtained by multiplying the bond strength $f_{bd,PIR}$ according to EN 1992-1-1:2004+AC:2010 with the factor $k_{b,seis}$ according to Table C4.

The minimum concrete cover according to Annex B3 and $c_{min,seis} = 2 \varnothing$ applies.

Table C4: Bond efficiency factor $k_{b,seis}$ related to concrete class and drilling method

$k_{b,seis}$ for perforation with hammer drill (HD), hollow drill bit (HDB) and compressed air drill (CA)	Concrete class							
	C16/20	C20/25	C25/30	C30/37	C35/45	C40/50	C45/55	C50/60
$\varnothing 12$ to $\varnothing 25$	1,00	1,00	0,85	0,77	0,68	0,62	0,58	0,53
$\varnothing 28$ to $\varnothing 32$	1,00	0,87	0,74	0,67	0,59	0,54	0,50	0,47

Table C5: Design values of the ultimate bond resistance $f_{bd,PIR,seis}$ ¹⁾ for hammer drilling (HD), hollow drill bit (HDB) and compressed air drill (CA)

Rebar diameter [mm]	Design values of the ultimate bond resistance $f_{bd,PIR,seis}$ [N/mm ²]							
	C16/20	C20/25	C25/30	C30/37	C35/45	C40/50	C45/55	C50/60
$\varnothing 12$ to $\varnothing 25$	2,00	2,30	2,30	2,30	2,30	2,30	2,30	2,30
$\varnothing 28$ to $\varnothing 32$	2,00	2,00	2,00	2,00	2,00	2,00	2,00	2,00

¹⁾The values given are valid for good bond condition according to EN 1992-1-1:2004.

For all other bond conditions multiply the value by 0,7.

**Injection system XTREME GRIP VINYLESTER
for rebar connections**

Performances
Design values of the ultimate bond resistance $f_{bd,PIR,seis}$

Annex C2
of European
Technical Assessment
ETA-19/0841

Design value of the ultimate bond stress $f_{bd,fi}$ under fire exposure for concrete classes C12/15 to C50/60 (all drilling methods):

The design value of the bond strength $f_{bd,fi}$ under fire exposure has to be calculated by the following equation:

$$f_{bd,fi}(\theta) = k_{fi}(\theta) \cdot f_{bd,PIR} \cdot \frac{\gamma_c}{\gamma_{M,fi}}$$

If $21^\circ\text{C} \leq \theta \leq 271^\circ\text{C}$: $k_{fi}(\theta) = \frac{17,563 \cdot e^{-0.01\theta}}{f_{bd,PIR} \cdot 4,3} \leq 1,0$

If $\theta > 271^\circ\text{C}$: $k_{fi}(\theta) = 0$

$f_{bd,fi}(\theta)$ = Design value of the ultimate bond stress in case of fire exposure in N/mm²

(θ) = Temperature in °C in the mortar layer

$k_{fi}(\theta)$ = Reduction factor under fire exposure

$f_{bd,PIR}$ = Design value of the ultimate bond stress in N/mm², according to Table C3 considering the concrete class, the rebar diameter, the drilling method and the bond conditions according to EN 1992-1-1:2004+AC:2010

γ_c = Partial safety factor according to EN 1992-1-1:2004+AC:2010

$\gamma_{M,fi}$ = Partial safety factor according to EN 1992-1-2:2004+AC:2008

For evidence under fire exposure the anchorage length shall be calculated according to EN 1992-1-1:2004+AC:2010, Equation 8.3 using the temperature-dependent ultimate bond stress $f_{bd,fi}$.

Figure C1: Example graph of reduction factor $k_{fi}(\theta)$ for concrete classes C20/25 for good bond conditions:

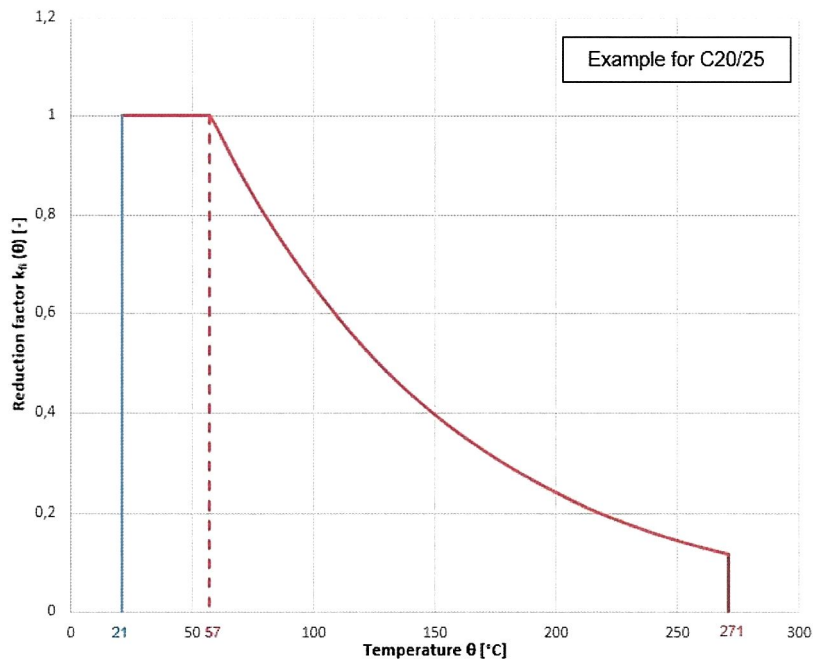

**Injection system XTREME GRIP VINYLESTER
for rebar connections**

Performances

Design values of bond strength $f_{bd,fi}(\theta)$ under fire exposure with temperature reduction factor $k_{fi}(\theta)$

Annex C3
of European
Technical Assessment
ETA-19/0841